

PWM Servo Amplifier

- CI [Commercial Information](#)
- FT [Features](#)
- TS [Technical Specifications](#)
- ES [Electrical Specifications](#)
- MS [Mechanical Specifications](#)
- MP [Technical drawings](#)
- IN [Installation Notes](#)
- CN [Wiring Notes](#)
- DV [Developer Specifications](#)
- US [User Information](#)



Commercial Information

Manufactured by Advance Motion Controls
 Ref.Manufacturer 30A8DD(direction) 50A8DD(motor wheels)
 Distributed by
 Ref. Distributer

ORDERING INFORMATION:
 Models: 30A8DDX, 25A20DDX, 50A8DDX, 50A20DDX
 X indicates the current revision letter.

General Features

- Surface-mount technology
- Small size, low cost, ease of use
- Optically isolated digital inputs
- Adjustable current limit
- Built-in PWM generator for self-test
- Four quadrant regenerative operation

DESCRIPTION: The 50A-DD Series PWM servo amplifiers are designed to drive brush type DC motors. The PWM frequency is determined by the PWM input signal. All models are fully protected against over-voltage, over-current, over heating and short circuits across motor, ground and power leads. All models interface with digital controllers that have a digital PWM output. They can also be used as a stand-alone system when using Pot 2. The 50A-DD Series amplifiers require only a single unregulated DC power supply as all logic and control voltages are generated internally. PWM input determines the output duty cycle. "Direction In" determines which side of the "H bridge" output is switching. Current limit can be reduced by Pot 1 (14 turn potentiometer), by DIP the switches and/or by an external current limiting resistor. The voltage at the current monitor pin P1-15 is proportional to the actual motor current.

Technical Specifications

	MODELES			
POWER STAGE SPECIFICATIONS	30A8DD	25A20DD	50A8DD	50A20DD
DC SUPPLY VOLTAGE	20 - 80 V	40 - 190 V	20 - 80 V	40 - 190 V
PEAK CURRENT (2 sec. max.,	± 30 A	± 25 A	± 50 A	± 50 A

internally limited)				
MAXIMUM CONTINUOUS CURRENT (internally limited)	± 15 A	± 12.5 A	± 25 A	± 25 A
MINIMUM LOAD INDUCTANCE*	150 µH	250 µH	150 µH	250 µH
SWITCHING FREQUENCY	5 - 20 kHz ±15%			
HEATSINK (base) TEMPERATURE RANGE	25° to + 65° C, disables if > +65° C			
POWER DISSIPATION AT CONTINUOUS CURRENT	60 W	125 W	100 W	250 W
OVER-VOLTAGE SHUT-DOWN (self reset)	85 V	195 V	85 V	195 V

* "Pancake" and "basket-wound" motors require external inductors.

Electrical Specifications

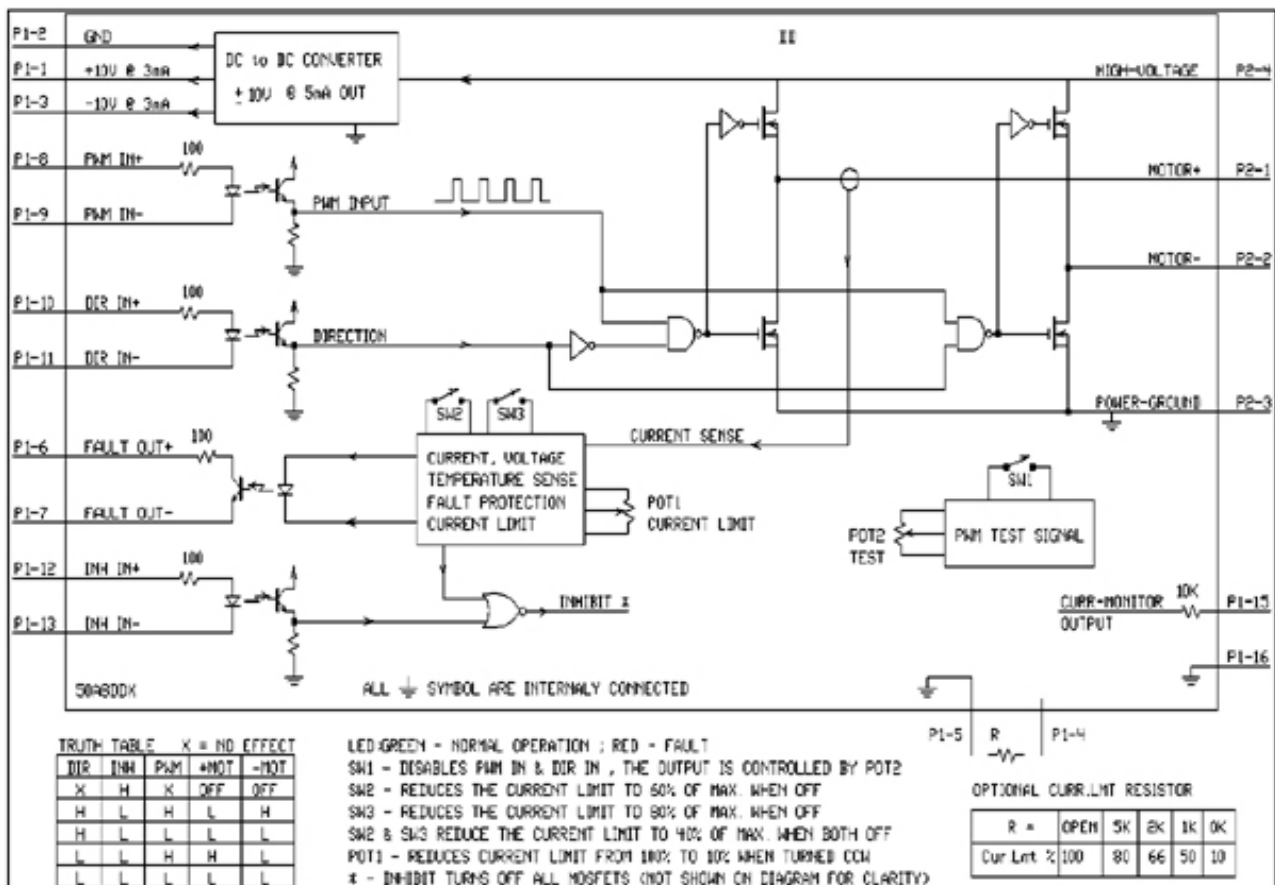

Mechanical Specifications

POWER CONNECTOR	Screw terminals
SIGNAL CONNECTOR	Molex connectors
SIZE	7.35 x 4.40 x 1.00 inches 186.7 x 111.7 x 25.4 mm
WEIGHT	1.5 lb. 0.68 kg

Installation Notes

CURRENT LIMITING:

Current limit can be reduced by Pot 1 by the DIP switches and/or by an external current limiting resistor. See functional block diagram. Pot 1 is a 14 turn potentiometer with one inactive turn at each end. The voltage at the current monitor pin P1-15 is proportional to the actual motor current.

POWER SUPPLY RECOMMENDATIONS:

An isolated power supply should be used with this series of amplifiers.